

(DOUBLE THERMOSTAT OVERRIDE RELEASE)
FOR MODULATING COMBINATION FIRE / SMOKE DAMPERS



Prior to today's advancements in smoke control techniques, fan systems were required to shut down during fire conditions and fire dampers were closed by heat. Air pressures were not utilized for the control and containment of smoke. In recent years, the requirement that systems completely shut down and fire dampers close and remain closed during fire conditions, has been questioned. Current Combination fire/smoke dampers may need to operate at temperatures above and beyond their initial closure rating. United Enertech's DTO/R option provides the capability to override rated damper closure from a secure remote location (such as a fire fighter's smoke control command of a remotely located control to permit utilization of the HVAC/Engineered Smoke Control System, but only until such time as the fire conditions exceed the maximum design limit. The DTO/R options also permits a combination fire/smoke damper to be reopened after a fire emergency has been controlled providing the temperatures at the damper have cooled down below the maximum design limit. Please note that the DTO/R option is recommended only for use in systems utilizing an Engineered Smoke Control design.

The DTO/R option is available on all United Enertech F/S-AFM Model Combination Fire/Smoke Dampers.

Devices to right of dashed line are factory mounted on damper.

Field wiring terminates at splice points indicated by "X"

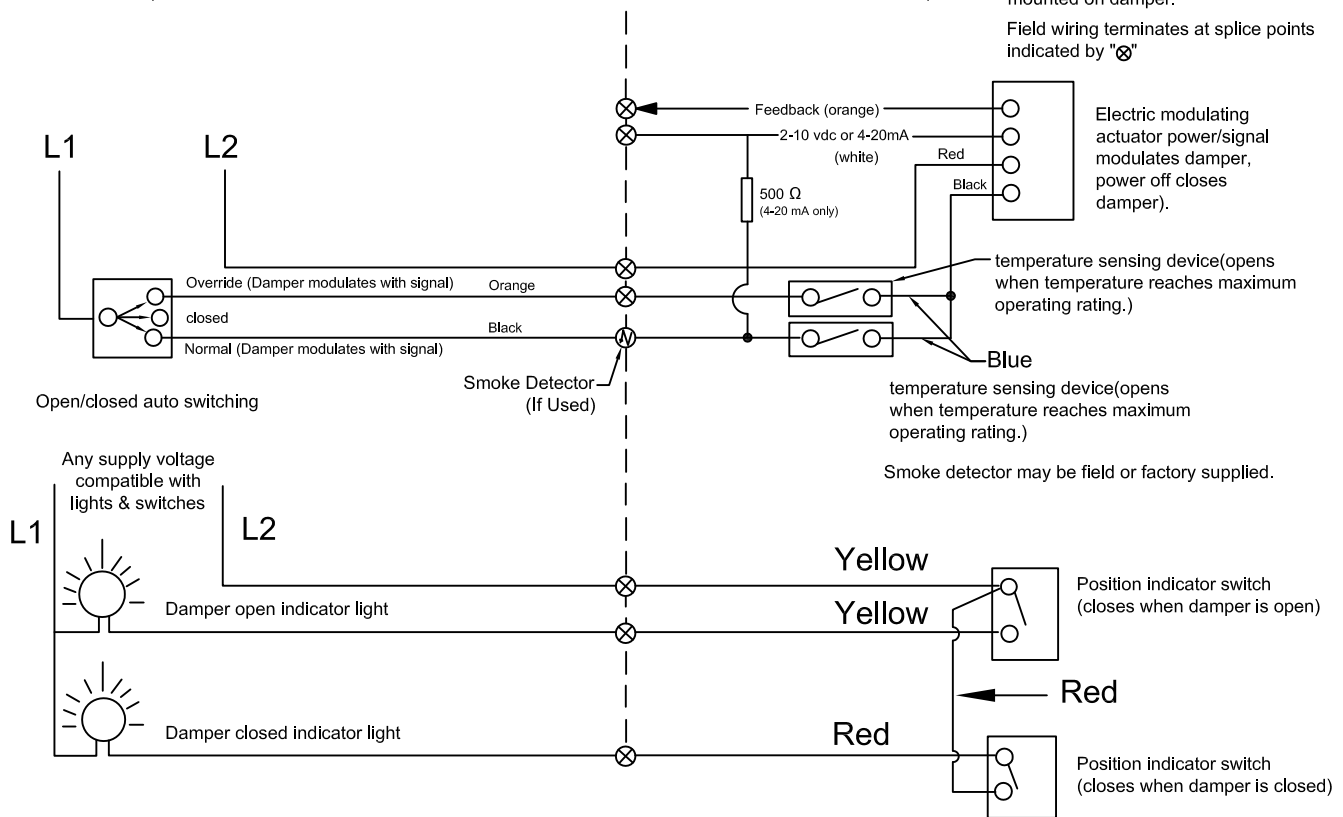

Switch is in Normal Position, damper motor is energized until thermostat senses temperature above initial closure rating. Above temperature closure rating, the damper motor is de-energized and damper closes.

Switch may then be moved to the Override Position and the damper will re-energize and remain energized until maximum operating temperature is reached. Once this temperature has been reached the damper motor is de-energized and the damper closes.

Switch in Closed Position damper motor is de-energized and damper is closed. Detailed wiring diagrams including terminal designation and/or wire color coding furnished with each shipment. Damper actuator may also receive a 2-10 vdc feedback signal for balancing purposes, however once the temperature closure rating is reached, the actuator will fail closed.

Indicator Switch Electrical Limitations

- 10 Amperes, 1/4 HP, 120 or 240 Volts A.C.
- .5 Ampere, 125 Volts D.C.
- .25 Ampere, 250 Volts D.C.
- 5 Amperes, 120 Volts (Lamp Load)
- 15 Amperes, 24 Volts D.C.

Manufacturer's Recommendations

All moving parts of the damper must be inspected and cycled at intervals not greater than every 12 months or in accordance with the latest edition of NFPA 90A, 92A, local codes and the actuator manufacturer. In addition, fuse links shall be removed and inspected for corrosion. Dry lubricants are recommended.